

OPTIONAL DISCONNECT HANDLE

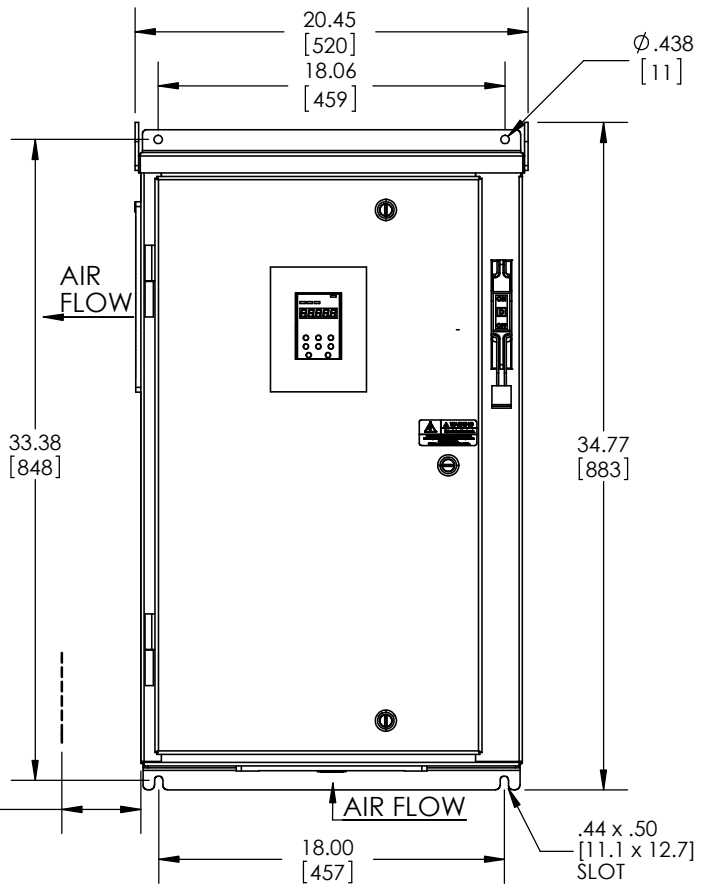

4.00 [102] MINIMUM CLEARANCE WHEN EXHAUST GRILLE IS PRESENT

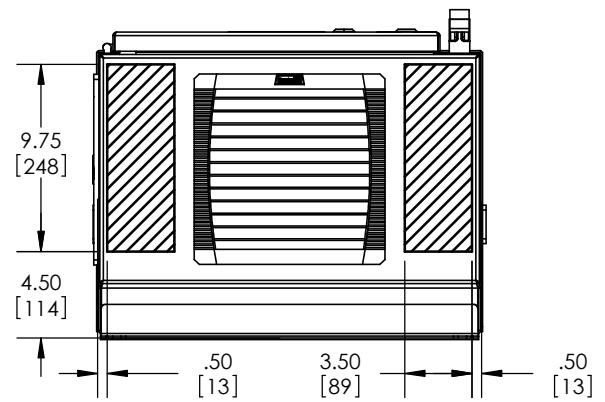

- NOTES:  
 A. FOR REFERENCE ONLY UNLESS PROPERLY ENDORSED. FOR ADDITIONAL DETAILS AND SPECIFICATIONS, CONSULT FACTORY.  
 B. DIMENSIONS ARE IN INCHES [MILLIMETERS].  
 C. HATCHED AREA INDICATES PERMISSIBLE CONDUIT ENTRANCE AREA.  
 D. FANS, FILTERS OR CLOSING PLATES ARE SUPPLIED WHEN OPTION MIX NECESSITATES.  
 E. USE APPROPRIATE TYPE RATED HUBS OR FITINGS TO MAINTAIN ENCLOSURE RATING.

	DRAWN:	DJP	DATE:	08/30/11	TITLE:	
	CHECKED:	DC	DATE:	08/30/11	DIMENSION DRAWING	
THIS DOCUMENT AND INFORMATION CONTAINED IN IT ARE CONFIDENTIAL, AND CANNOT BE COPIED OR DISCLOSED IN WHOLE OR IN PART WITHOUT THE EXPRESS WRITTEN CONSENT OF YASKAWA AMERICA INC.	TECH:	JZ	DATE:	08/31/11	MATERIAL#	---
	APPROVED:	DJP	DATE:	08/30/11	SIZE	REVISION
	ORIGINAL DESIGN:	DJP	DATE:	08/30/11	A	00
					PAGE	1 OF 1
				DRAWING #: DD.AP1.112.W2.01		